

VELOCITY SERIES

A



DESCRIPTION

The Fantech Velocity ceiling mounted header box fan features quiet operation and powerful air flow performance. It includes a fully optimised inlet cone, low resistance backdraft damper and centrifugal impeller that maximises air pressure and ensures rooms such as ensuites and bathrooms are quickly cleared of steam and unpleasant odours. It includes a unique swing clip and easy to attach spigot that makes it fast to install into a standard 10" round fan cut out.

Typical Applications

Exhausts from residential or light commercial applications such as toilets, bathrooms, laundries, kitchens and ensuites. Its low profile compact design and side exhaust outlet makes it suitable for mounting between floors and applications with low ceiling heights such as cathedral ceilings.

Features

- Advanced impeller and housing design provides powerful air flow and minimises noise
- High strength swing clips make installation easy
- Low resistance non-return backdraft damper maximises air flow performance
- Easy to remove diffuser makes cleaning simple
- Can be retrofitted into a standard 10" round fan cut out
- Fitted plug and lead simplifies installation
- Available with a 3 to 15 minute adjustable run-on timer

Construction

Housing and diffuser are made from injected moulded poly-propylene. Fans are forward-curved centrifugal, driven by a squirrel cage motor.

Motor

Type - squirrel cage induction motor.
Electricity supply - 230V, single-phase, 50Hz.
Bearings - sealed for life, ball.
See pages O-2/3 for details on these motors.

Internal Thermal Protection

Automatic reset thermal protection is fitted as standard

Testing

Air flow to ISO5801: 2007
Noise to ISO3744: 2010

Special Note

Timer model ECL29-150RDWT includes a plug and lead to suit HPM 4 and Clipsal bases with 4 pin sockets.

SPECIAL FEATURES

Easy duct connection

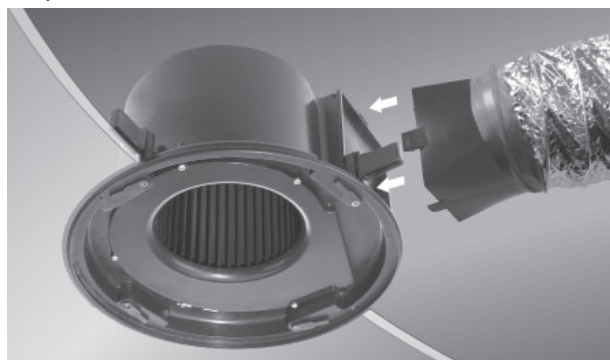

Long clip-in spigot makes installation and duct connection easier.

Installation is made easy



Rotate swing clips to hold fan body in place.



Tighten screws so clips clamp onto ceiling board.

SUGGESTED SPECIFICATION

The ceiling fans shall be of the Fantech Velocity Header Box Series as designed by Fantech Pty Ltd. and be of the model number shown on the schedule/drawing.

Impellers shall be forward-curved centrifugal and driven by a squirrel cage motor with integral thermal protection. They shall be fitted with high strength swing clips, removable spigot, low resistance non-return backdraft damper and removable diffuser. They shall include a plug and lead, and its housing and diffuser be made of injected moulded polypropylene.

They shall be tested to ISO5801: 2007 for air flow and ISO3744: 2010 for noise.

PERFORMANCE CURVE

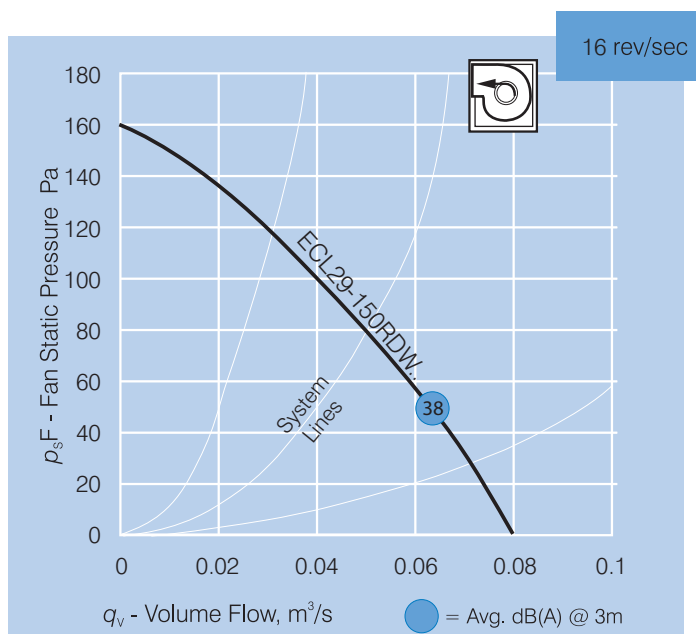

TECHNICAL DATA

Model Number	Fan Speed rev/sec	Avg. dB(A) @ 3m	Watts	Amps	App. Wt. kg
ECL29-150RDW..	16	38	40	0.17	3

DIMENSIONS

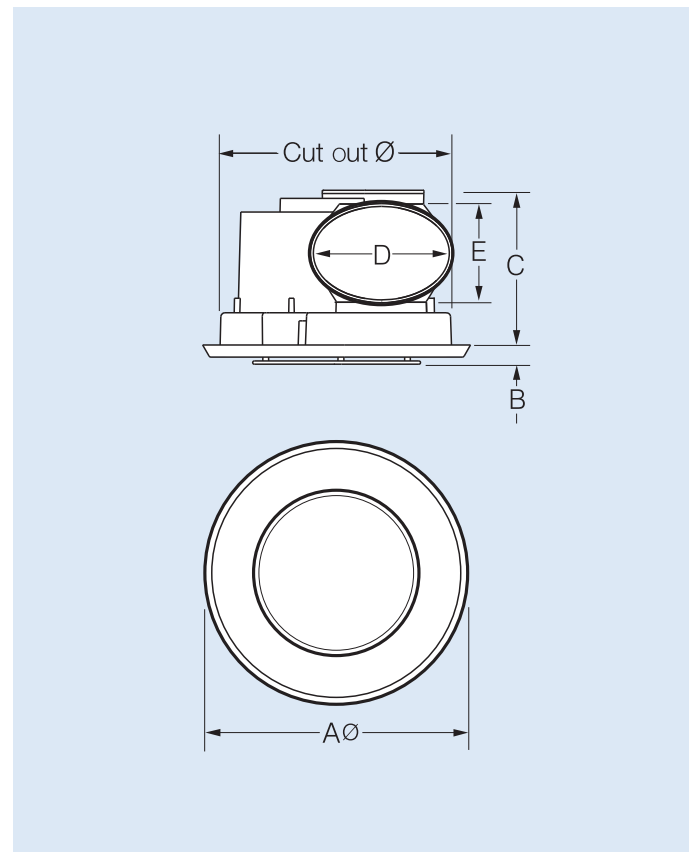

Model Number	Description	Cut out Ø	Dimensions, mm				
		A	B	C	D	E	
ECL29-150RDW..	Round diffuser	290	332Ø	25	192	170	120

HOW TO ORDER

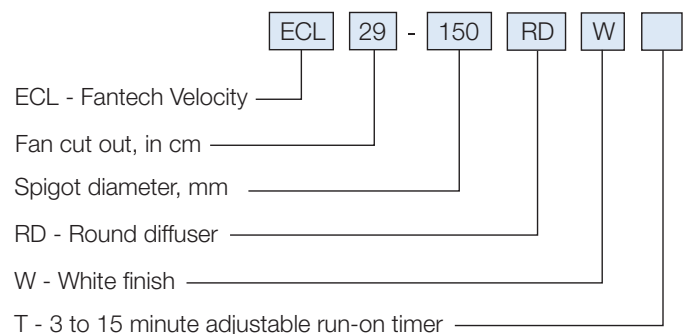

ANCILLARY EQUIPMENT

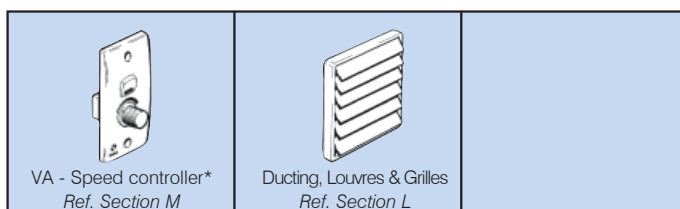

* Not suitable for models with run-on timers



Scan the QR Code to view more information online.

