

POWER SENSE SWITCH TYPE - VZ-ISNSE



The VZ-ISNSE is a 240V AC power sense switch that provides automatic on/off control of a fan or exhaust fan system. The unit detects the current of an appliance such as a clothes dryer, closing and opening the switched output relay when the load sense range parameters are met.

Can be used with the VZ2-10TS, VZM0-28TS, VZ6-4PL or as a stand alone unit.

LED's indicate when load is activated.

Warning

Not to be used with fans with EC motors or inverters.

TECHNICAL DATA

Model Number	Load Sense Range	Switched Output Max. Amps	Enclosure Size, mm
VZ-ISNSE	On = 2.5 - 15 amp Off = 0 - 1.5 amps	5	153W x 110H x 60D

SUGGESTED WIRING ARRANGEMENT

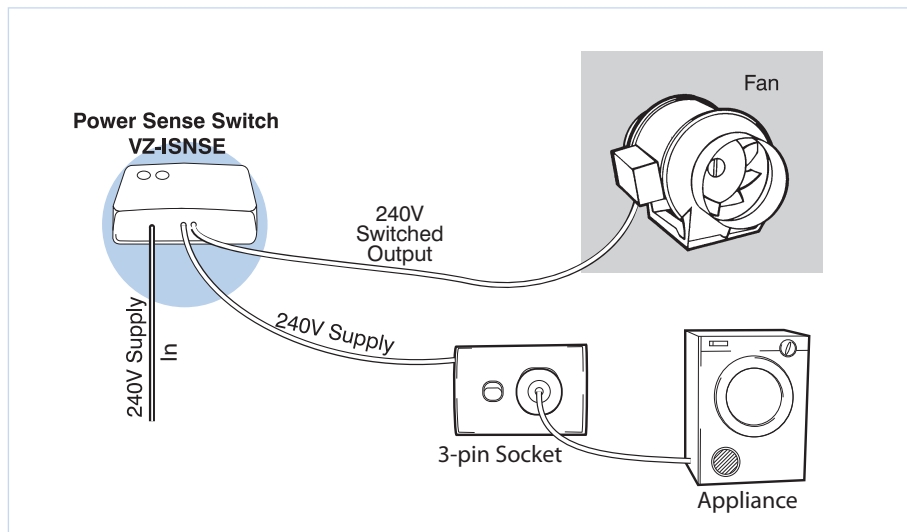

FAN CONTROL THERMOSTAT



The Fantech Fan Control Thermostat has been developed to control the operation of a 240-volt fan based on the setting made on the thermostat dial.

It can be set to turn on a fan when the room temperature is either higher or lower than the set point. This makes it an ideal addition for Heat Transfer Kits as it turns on the fan to efficiently transfer warm air from one room to another when the temperature falls below the thermostat's set point. It can also be used with supply air systems to provide fresh air to a given space when the temperature reaches the dial setting.

The Thermostat can also be used in applications such as computer server rooms, switch rooms and commercial kitchens where the accumulation of hot air needs to be extracted through the use of a ceiling, wall-mounted or in-line fans.

TECHNICAL DATA

Model Number	Temperature range	Mounting	Maximum Amps	Dimensions, mm
TFC6	5°C to 30°C	Wall mountable	6.0	86W x 86H x 33D

SELECTION TABLE

The TFC6 is suitable for most 240-volt fans.

The TFC6 can be set in two modes:

- Cool mode - will start the fan when the room temperature is higher than the set point.
- Heat mode - will start the fan when the room temperature is lower than the set point.

WIRING DIAGRAM

