

# SHORT CASE AXIAL SERIES



## DESCRIPTION

The Short Case Axial Series has a light-weight but robust construction and is designed for ducted systems. They feature a galvanised steel casing with a polyester epoxy finish and are capable of operating in ambient temperatures ranging from -20 °C to +70 °C.

The range is available in three motor options; Standard, High Performance (HP), and Speed Controllable (SC) by Variable Speed Drive.

There are 8 sizes in the range extending from 250 to 630mm diameter.

## Typical Applications

Exhausting or supplying air in a wide range of commercial and industrial applications.

## Features

- Compact, short case design.
- Light-weight but robust construction.
- Most motors fitted to the 415V/3-phase Short Case Axial Series are a 2-speed, star/delta design.
- An electric junction box is fitted as standard.
- When being speed controlled the maximum allowable ambient is 50 °C.
- Can be mounted in any position.
- An extensive range of matched ancillary equipment is available.

## Construction

The casing is of galvanised steel with a polyester epoxy finish as standard. Impeller blades are of GRP. Aluminium blades are an optional extra.

## Motors

Type - squirrel cage induction motor.

Electricity supply - 230V single-phase or 415V three-phase, 50Hz.

Bearings - sealed-for-life, ball.

Speed-controllable using electronic or auto-transformer controllers or for SC models Variable Speed Drives can be used.

Enclosure IP55.

See pages O-3/4 for details of these motors.

## Internal Thermal Protection

Integral thermal protection is supplied as standard.

## Testing

Air flow tests to ISO 5801: 2004.

Noise tests to BS848, Part 2, 1985.

## HOW TO ORDER

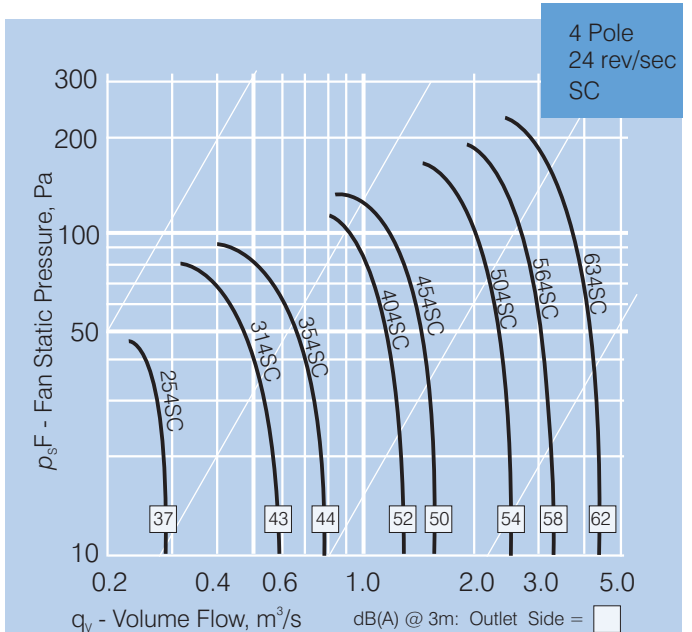
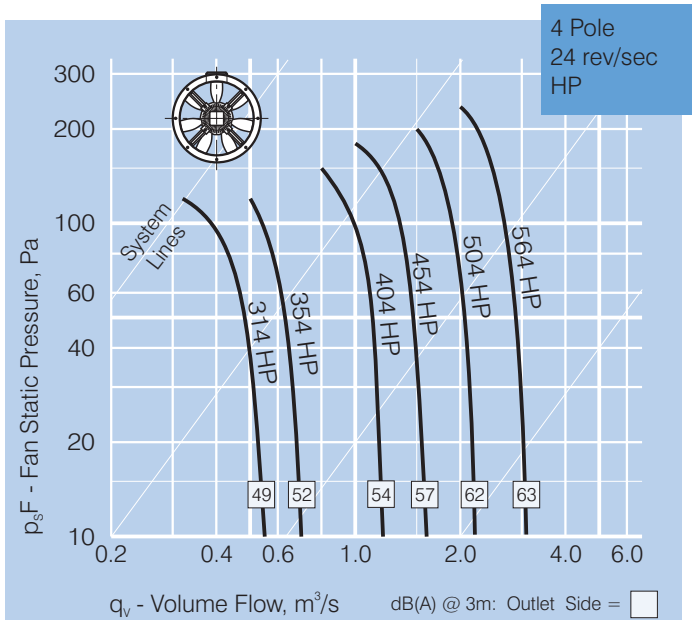
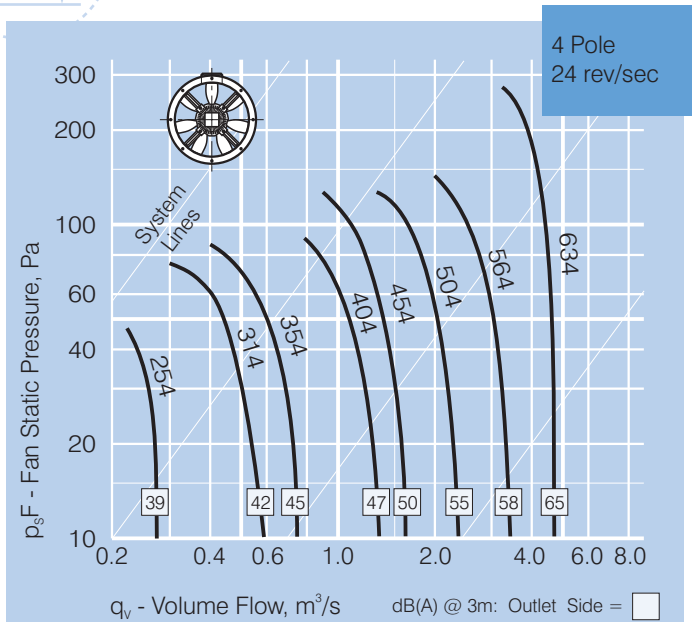
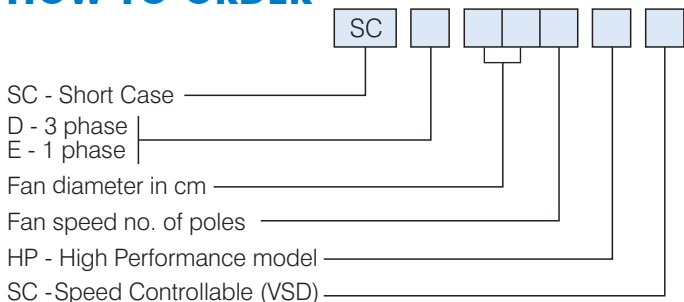

## Wiring Diagram

See pages N-6/7, diagram DD 4, 5, 6, & 7

# SHORT CASE AXIAL SERIES

## SUGGESTED SPECIFICATION

The Short Case Axial Series shall be as supplied by Fantech Pty Ltd. The axial impellers shall be of GRP and driven by single-phase or three-phase motors with integral thermal protection.

Casings shall be of galvanised steel construction with a polyester epoxy finish.

All models shall be fully tested to ISO 5801: 2004 for air flow and BS848: Part 2, for noise.

## TECHNICAL DATA

Model	Fan. Speed	Avg. dB(A) @ 3m	SCE.. 1 ph.		SCD.. 3 ph.		App. wt
SCE..	rev/sec		kW	Amps	kW	Amps	kg.
254	23	39	0.09	0.90	0.12	0.50	8.0
254SC	23	37	-	-	0.12	0.41	8.0
314	23	42	0.09	0.90	0.12	0.50	8.5
314HP	23	49	0.09	0.90	0.12	0.50	8.5
314SC	23	43	-	-	0.12	0.41	8.5
354	23	45	0.09	0.90	0.12	0.50	9.0
354HP	23	52	0.09	0.90	0.12	0.50	9.0
354SC	23	44	-	-	0.12	0.41	9.0
404	23	47	0.25	1.80	<b>0.37</b>	<b>1.40</b>	12.0
404HP	23	54	0.25	1.80	<b>0.37</b>	<b>1.40</b>	12.0
404SC	23	51	-	-	0.25	0.68	12.0
454	23	50	0.25	1.80	<b>0.37</b>	<b>1.40</b>	14.0
454HP	23	57	0.25	1.80	<b>0.37</b>	<b>1.40</b>	14.0
454SC	23	49	-	-	0.25	0.68	14.0
504	23	55	0.55	3.60	<b>0.55</b>	<b>1.75</b>	20.0
504HP	23	62	0.55	3.60	<b>0.55</b>	<b>1.75</b>	20.0
504SC	23	54	-	-	0.55	1.35	20.0
564	23	58	0.75	4.9†	<b>0.75</b>	<b>2.00</b>	22.0
564HP	23	63	0.75	4.9†	<b>0.75</b>	<b>2.00</b>	22.0
564SC	23	57	-	-	0.75	1.76	22.0
634	23	65	-	-	<b>1.50</b>	<b>4.30</b>	24.0
634SC	24	61	-	-	1.10	2.68	24.0

Electrical data in bold type denotes 2-speed star/delta motors are fitted.







Amperages shown are a guide only. Refer to our Sales Department for accurate figures at time of order. † Use auto transformer control only.

## NOISE DATA

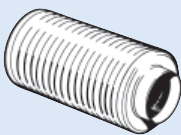
Model	In-duct Sound Power Levels							
	$L_w$ dB re 1pW							
SCE..	63	125	250	500	1k	2k	4k	8k
254	63	61	57	57	55	52	48	43
254SC	59	65	60	51	52	48	42	38
314	64	63	60	60	58	55	51	46
314HP	65	69	69	62	65	64	57	44
314SC	65	71	66	57	58	54	48	44
354	67	66	63	63	61	58	54	49
354HP	68	72	72	65	68	67	60	47
354SC	63	73	67	58	59	56	50	43
404	69	68	65	64	64	60	56	50
404HP	68	70	70	69	71	69	61	52
404SC	74	77	69	69	65	65	62	59
454	72	71	68	67	67	65	59	53
454HP	71	73	73	72	74	72	64	55
454SC	69	75	67	67	64	64	60	54
504	75	75	71	72	71	68	62	57
504HP	73	74	74	76	79	76	74	62
504SC	72	78	70	70	69	68	66	60
564	79	79	75	74	75	71	68	61
564HP	76	74	77	78	80	77	75	66
564SC	80	79	74	75	72	71	69	65
634	85	77	81	82	80	79	76	70
634SC	78	83	78	78	76	76	74	69

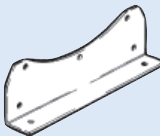
The In-Duct Sound Power Levels are for the Outlet Side of the fan. Inlet Side levels are generally 1-2dB lower. The levels are based on the fans operating at approximately 50% of peak pressure.

## ANCILLARY EQUIPMENT

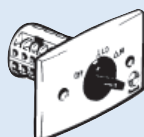
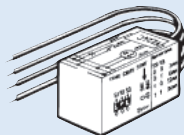
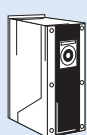
 CC - Circular Attenuator Ref. Section H	 Vibration Isolators Ref. Section I	 CMF - Matching Flange Ref. Section J
 CFT - Mounting Feet Ref. Section J	 CIC - Inlet Cone Ref. Section J	 DG - Finger Guards Ref. Section J
 Shutters Ref. Section L	 VA - Speed controller Ref. Section M	 SD - Star/Delta switch Ref. Section M
 VZ - Run-on timer Ref. Section M	 Variable speed drives Ref. Section M	

## DIMENSIONS

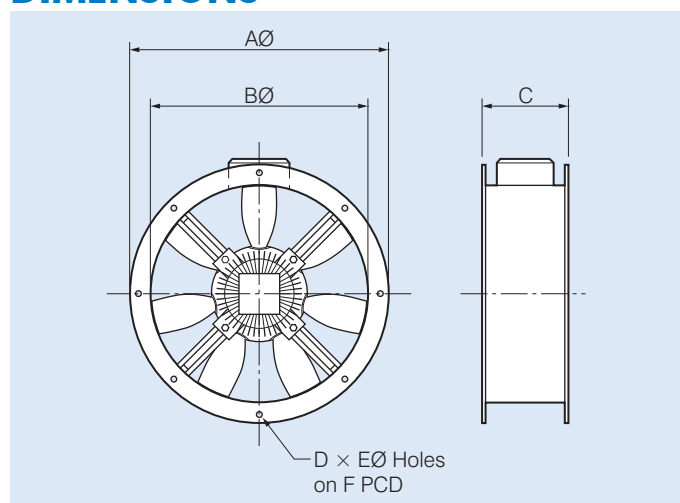

Model	Dimensions, mm						
	SC..	AØ	BØ*	C	D	EØ	F
254		305	250	180	8	7.0	285
314		382	315	180	8	9.5	356
354		421	350	180	8	9.5	395
404		466	400	190	12	9.5	438
454		515	450	190	12	9.5	487
504		567	500	250	12	9.5	541
564		636	560	250	16	11.5	605
634		709	630	250	16	11.5	674

\* Dimension B is internal for the casing.

Scan the QR code to view more information online.

