

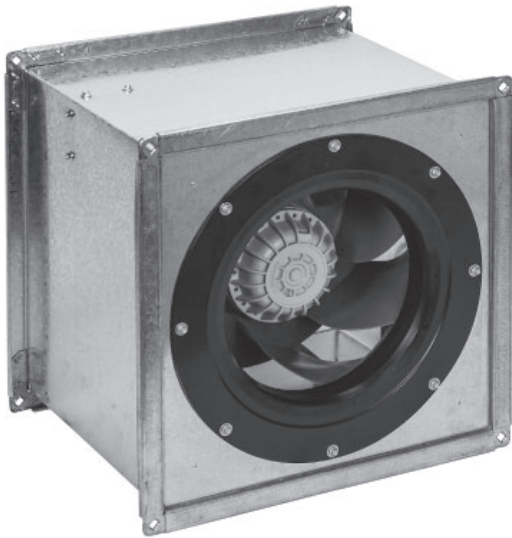





## ANCILLARY EQUIPMENT

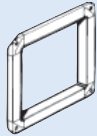

 Vibration Isolators Ref. Section I	 POW - Matching Flanges Ref. Section J	 FT - Mounting Foot Ref. Section J
 SD - Star/Delta switch Ref. Section M	 Variable speed drives Ref. Section M	 VA - Speed controller Ref. Section M

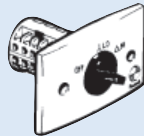
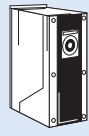
### DESCRIPTION

The PowerLine Ultra Series of In-Line Mixed-Flow Fans is designed for a wide range of duct mounted applications. They are most suitable in commercial and industrial applications where medium pressure is required. They are available in various speed options and 9 sizes, extending from 250 to 630mm diameter.

### Typical Applications

Commercial and industrial supply or exhaust air applications such as shopping centres, office buildings, exhibition centres, hotels, health centres, schools and universities.

### Features

- Robust, yet lightweight galvanised steel construction.
- Easy to fit 35mm TDF profile flange connections.
- Choice of external rotor or standard direct-drive motors.
- Large choice of speeds available.
- Most 3-phase external rotor motors fitted are 2-speed star/delta design.
- To improve energy efficiency, motors can be speed-controlled.
- Can be mounted in any position.
- A range of matched ancillaries is also available.

### Construction

Galvanised steel housings with 35mm TDF profile flange connections.

Mixed-Flow impellers are made from high performance injection moulded composite plastic material.

### Motors

Type - can be supplied with direct-driven external rotor or standard direct-drive motors.

Electricity supply - single or three-phase to suit a wide range of voltages and frequencies.

Bearings - sealed-for-life, ball.

External rotor motors are fully speed-controllable using electronic or auto-transformer controllers, however Sinusoidal filters are required when a variable speed drive is used.

Standard direct-drive motors can be single or multi-speed and can be speed-controlled using a variable speed drive.

See pages O-2/3 for details on external rotor motors and pages O-3/4 for details on standard direct-drive motors.

### Internal Thermal Protection

Automatic-reset type is fitted as standard to external rotor motors and is an optional extra on standard frame motors.

### Testing

Air flow tests based on ISO5801

Noise tests based on BS848:Part 2, 1985, or ISO13347-3

### Wiring Diagram

See pages N-8, diagrams ER1, 2, 3, 4, 5 for external rotor motors and N-6/7, diagrams DD1, 2, 3, 7, 9 for standard direct-drive motors.

### SUGGESTED SPECIFICATION

The duct mounted fans shall be of the In-line Mixed-Flow PowerLine Ultra Series as designed and manufactured by Fantech Pty. Ltd. and be of the model numbers shown on the schedule/drawings.

They shall include galvanised steel housings with 35mm TDF profile flange connections.

The Mixed-Flow impellers shall be made from high performance injected moulded composite plastic and driven by external rotor or standard direct-drive motors as nominated.

All performance data shall be for a complete assembled unit based on ISO5801 for air flow and BS848: Part 2, 1985 or ISO13347-3 for noise.

### HOW TO ORDER

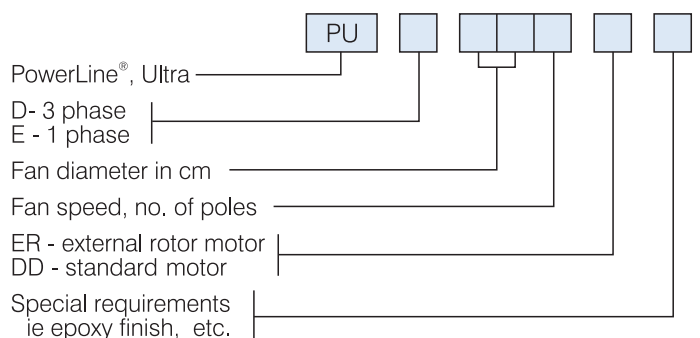

# POWERLINE ULTRA SERIES

## Note

Performance curves shown are based on nominal speeds.

As motor speeds may vary from one manufacturer to another, and from one motor type to another, it is possible actual fan speeds may differ and, therefore, the performance of the fan.

For Direct-Drive performance refer to Fans by Fantech Selection Program.

## DIMENSIONS

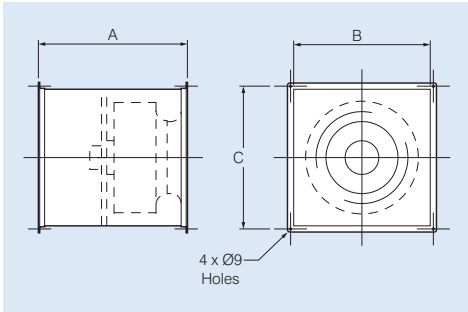

Model	Dimensions, mm				App. wt.
PUD..	A*	A**	B□	C□	kg#
25.	430	330	325	358	27
28.	450	350	350	383	29
31.	500	400	400	433	32
35.	550	425	450	483	36
40.	550	450	500	533	48
45.	600	475	550	583	55
50.	700	500	650	683	67
56.	800	550	725	758	101
63.	850	550	800	833	138

\* Fan with direct-drive motor - DD

\*\* Fan with external rotor motor - ER

# Weight for fan with direct-drive motor only

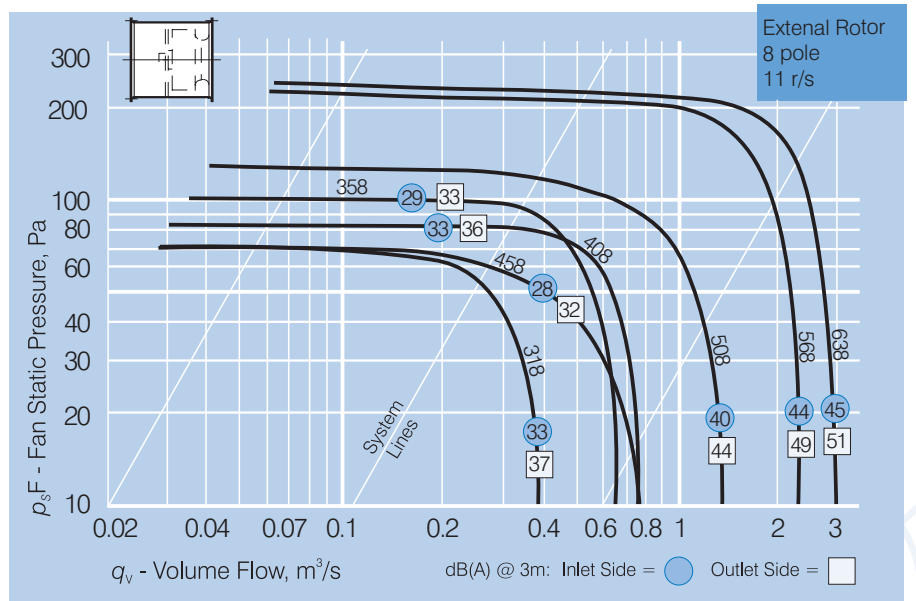
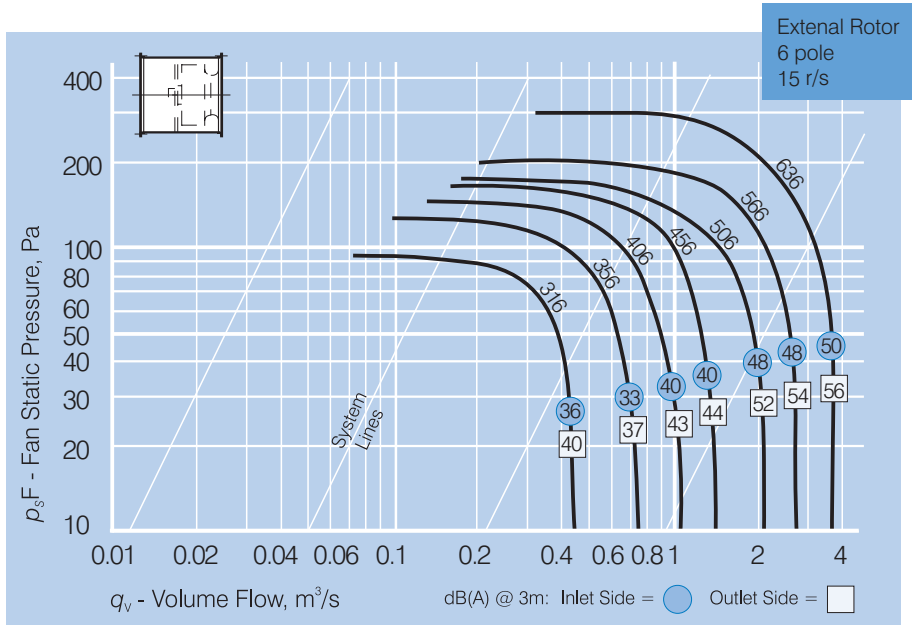
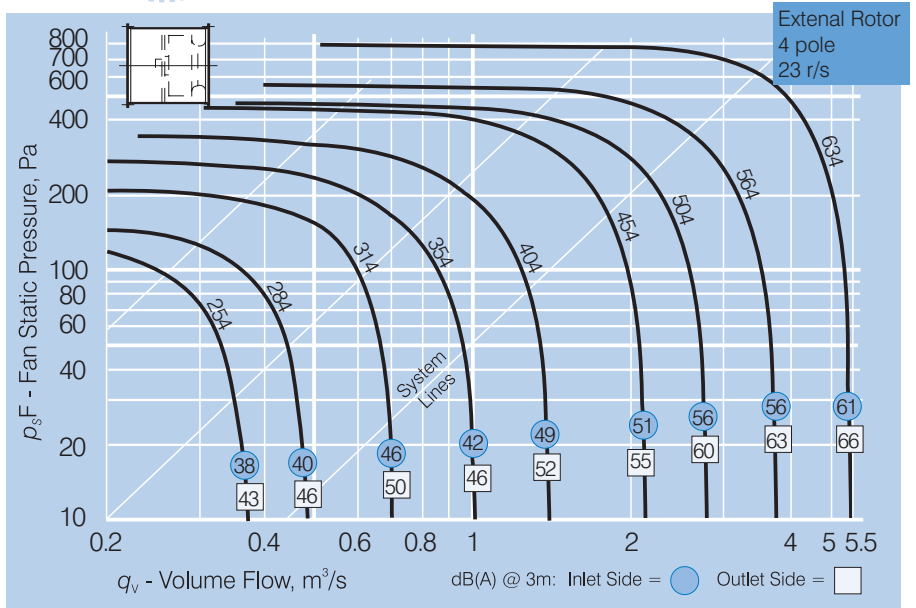

# POWERLINE ULTRA SERIES

## TECHNICAL DATA & NOISE LEVELS

Model PUD... PUE..	Nom. speed, rev/sec	Max. Operating Temp °C	PUD/PUE... AVG. dB(A) @ 3m	PUE...ER 1 ph.		PUD...ER 3 ph.		PUE...DD 1 ph.		PUD...DD 3 ph. kW*	In-Duct Sound Power Levels, dB								
				kW	Amps	kW	Amps	kW	Amps		63	125	250	500	1k	2k	4k	8k	
254**	24	60	Inlet	38	0.10	0.48	-	-	0.09	0.09	0.37	65	59	55	55	54	53	48	41
			Outlet	43								64	61	59	58	58	60	54	46
284**	24	60	Inlet	40	0.13	0.66	-	-	0.09	0.09	0.37	64	59	60	58	56	55	52	45
			Outlet	46								64	61	62	61	62	63	58	50
314	23	60	Inlet	46	0.22	1.10	0.21	0.50	0.25	1.80	0.37	74	70	64	62	60	60	59	53
			Outlet	50								74	71	64	65	64	66	61	56
316	15	60	Inlet	36	0.09	0.48	0.09	0.26	0.12	1.05	0.37	61	60	54	52	50	50	49	43
			Outlet	40								64	61	54	55	54	56	51	46
318	13	60	Inlet	33	-	-	0.05	0.11	-	-	-	58	57	51	49	47	47	46	40
			Outlet	37								61	58	51	52	51	53	48	43
354	23	60	Inlet	42	0.37	1.85	0.33	0.68	0.25	1.80	0.37	65	68	61	58	54	56	55	49
			Outlet	46								66	67	61	60	62	60	58	52
356	16	60	Inlet	33	0.12	0.56	0.13	0.36	0.12	1.05	0.37	56	59	52	49	45	47	46	40
			Outlet	37								57	58	52	51	53	51	49	43
358	13	60	Inlet	29	-	-	0.07	0.14	-	-	-	52	55	48	45	41	43	42	36
			Outlet	33								53	54	48	47	49	47	45	39
404	22	60	Inlet	49	0.58	2.60	0.54	1.20	0.75	4.90	0.75	69	73	66	66	60	63	62	56
			Outlet	52								71	71	66	67	68	67	64	58
406	15	60	Inlet	40	0.28	1.35	0.22	0.56	0.18	1.55	0.37	60	64	57	57	51	54	53	47
			Outlet	43								62	62	57	58	59	58	55	49
408	11	60	Inlet	33	-	-	0.13	0.28	-	-	-	53	57	50	50	44	47	46	40
			Outlet	36								55	55	50	51	52	51	48	42
454	23	60	Inlet	51	1.10	5.20	1.00	1.95	-	-	1.10	73	75	70	67	64	65	63	58
			Outlet	55								78	74	72	71	71	68	65	59
456	15	60	Inlet	40	0.37	1.75	0.32	0.70	-	-	0.37	62	64	59	56	53	54	52	47
			Outlet	44								67	63	61	60	60	57	54	48
458	9	60	Inlet	28	-	-	0.19	0.39	-	-	-	50	52	47	44	41	42	40	35
			Outlet	32								55	51	49	48	48	45	42	36
504	21	60	Inlet	56	1.65	7.40	1.45	2.80	-	-	1.50	77	81	76	71	70	69	66	61
			Outlet	60								85	81	82	73	76	72	67	60
506	14	60	Inlet	48	0.54	2.50	0.48	0.88	-	-	0.55	69	73	68	63	62	61	58	53
			Outlet	52								77	73	74	65	68	64	59	52
508	11	60	Inlet	40	-	-	0.31	0.50	-	-	-	61	65	60	55	54	53	50	45
			Outlet	44								69	65	66	57	60	56	51	44
564	22	45	Inlet	56	-	-	2.50	4.60	-	-	3.00	79	81	77	72	71	71	69	64
			Outlet	63								82	84	80	79	78	77	75	69
566	15	60	Inlet	48	0.84	4.20	0.86	2.20	-	-	0.75	73	73	69	64	63	64	59	52
			Outlet	54								75	76	71	70	70	69	64	57
568	13	60	Inlet	44	-	-	0.62	1.10	-	-	-	69	73	67	61	59	57	53	46
			Outlet	49								72	73	68	67	66	63	58	50
634	24	40	Inlet	61	-	-	-	-	-	-	5.50	71	82	79	78	77	76	72	68
			Outlet	66								74	85	82	85	83	81	77	69
636	15	60	Inlet	50	-	-	1.35	3.40	-	-	1.10	65	73	69	67	66	65	61	57
			Outlet	56								68	76	72	74	72	70	66	58
638	12	60	Inlet	45	-	-	0.86	1.85	-	-	-	65	67	65	61	61	59	55	49
			Outlet	51								69	71	68	70	67	64	59	50

\* Amperages for standard TE motors can be obtained at time of order. Check fan nameplate for exact amperage of all motors.

\*\* Sound data for single phase external rotor motors



Scan the QR Code  
to view more  
information online.