

INFILTRA FSU SERIES - AC SUPPLY



DESCRIPTION

The InFiltration Filtered Supply Unit has been designed to provide filtered outside air to a range of applications. Can be wired in high, medium and low speed and includes a high performance centrifugal impeller.

Typical Applications

Supplies fresh, clean filtered air for applications including classrooms (medium speed recommended) and dataroom or switchroom pressurisation (low, medium, high speeds).

Also suitable for areas that are typically serviced by under-ceiling air conditioning units where a direct supply fresh air intake is not possible or practical.

Features

- Durable and secure zinc coated steel housing, powder-coated 'Pearl White'.
- Designed for in-wall mounting.
- Weatherproof inlet grille.
- Powder-coated Centrifugal fan.
- 3-speed facility, connected on-site.
- F5 filter included as standard, see Special Notes
- Bushfire model fitted with stainless steel or bronze mesh
- Quarter-turn latch for easy filter access

Construction

Zinc coated, 'Pearl White' powder-coated steel housing. Integral weatherproof inlet grille providing security. Filter in fan discharge is standard.

Motors

Type - external rotor, squirrel cage induction motor.
Electricity supply- 230V, single-phase, 50Hz.
Bearings - sealed-for-life, ball.
Supplied with three speed facility, adjusted on site by a wiring change.
Class B motor, IP20.
See pages O-2/3 for details on these motors.

Internal Thermal Protection

Auto-reset type fitted as standard.

Testing

Air flow tests to ISO 5801:2017
Noise tests to ISO3744: 2010
Performances shown are based on clean filters.
As air flow will be affected by room pressurisation, care should be taken to ensure adequate air relief is provided.

DIMENSIONS

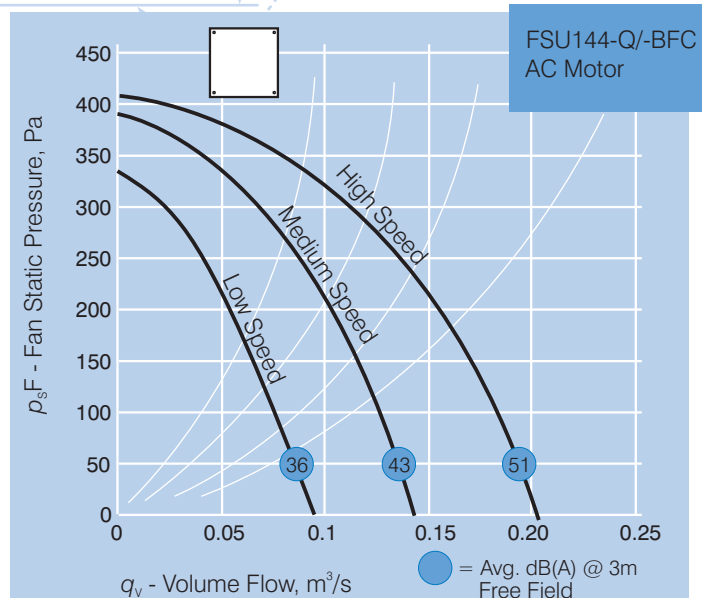
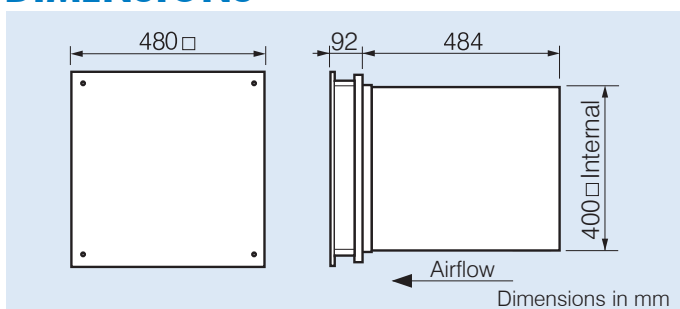

TECHNICAL DATA

Model Number	Speed Setting	Air Flow m ³ /sec	Avg. dB(A)* @ 3m	FSU.. 1 ph. Watts	1 ph. Amps	App. Wt. kg
FSU144-Q/-BFC	1 (Hi)	0.203	51	298	1.3	15
	2 (Med)#	0.143	43	207	0.95	
	3 (Lo)	0.095	36	178	0.82	

* dB(A) figures shown are free field
Medium speed (up to 43 dBA) is recommended for classroom type environments. The high speed setting @ 51dBA should not be used for classrooms.

Wiring Diagram

The unit is provided with a wiring strip mounted internally.

Active, Neutral and an Earth are required to be connected to the strip. On-Off switches are by others.

Wiring access is provided to allow wiring from inside the building. See online product page for wiring diagram.

Special Notes

Filter
A 345 x 345mm disposable filter is provided on the discharge side of the fan with a performance classification of F5 as tested in accordance with AS1324.2-2001 and rated as per AS1324.1-2001. These ratings are equivalent to the European 4/5 classification for filters as outlined in EN778. Access is obtained by un-doing two cap bolts on the sides of the diffuser panel and then removing the diffuser.

Installation

This unit is designed to be installed flush to the inside wall, except diffuser plate protrusion. Mounting holes and fasteners are by others. A penetration size of 410 x 410mm is required.

Bushfire Model: Bushfire compliant model includes stainless steel or bronze mesh that provides ember protection. Compliant to AS3959:2009 up to and including BAL-40.

SUGGESTED SPECIFICATION

The filtered supply air unit shall be of the InFiltration FSU Series as designed and manufactured by Fantech Pty Ltd and be of the model numbers shown on the schedule/drawing. The units shall incorporate a centrifugal impeller, external rotor motor and F5 filter media. Housing shall be manufactured from zinc coated steel, powder-coated in 'Pearl White'. All models shall be fully tested to ISO 5801:2017 for air flow and ISO 3744:2010 for noise.

HOW TO ORDER

Quote the model number shown in the technical data table above.

FSU144-Q: Standard model
FSU144-Q-BFC: Bushfire model

