



DESCRIPTION

The Alpha Series of supply air roof units have been designed for use in free intake or ducted installations. These robust but lightweight units are fitted with bird mesh as standard to prevent debris and birds entering the building and interrupting motor operation. There are 10 models in the series extending from 200 to 630mm diameter.

Typical Applications

Ideal for supplying fresh air to an air handling unit or to an air conditioning system. Also suitable where make-up air or positive pressure is required in the ventilated space.

Features

- Robust, corrosion-resistant construction with high performance axial flow impellers.
- Large choice of speeds available.
- The MV units have durable powder-coated steel blades. The AD/E units have GRP blades as standard with an option of aluminium, nylon or anti-static.
- Can be mounted at angles up to 30°.
- Some 3-phase motors are 2-speed star/delta design as standard.
- Speed-controllable using electronic or auto-transformer controllers.
- For centrifugal supply air units refer to pages D-32/33.

Construction

Cowls are of UV-stabilised plastic

Steel components have a corrosion resistant finish

MV units have powder-coated galvanised steel impellers

AD/E have GRP blades as standard with an option of aluminium, nylon or anti-static material where required

Bird-mesh guards are fitted as standard

Shutters cannot be fitted.

Motors

Type - MV - external rotor, squirrel cage induction motors

AD/E - squirrel cage induction motors

Electricity supply - 230V, single and 415V, 3-phase, 50Hz

Bearings - sealed-for-life, ball

Speed-controllable using electronic or auto-transformer controllers

See pages O-2/3 for details of motors in MV units and pages O-3/4 for details of the AD/E units

Internal Thermal Protection

Auto-reset protection is supplied on all MV units and manual-reset on the AD/E units.

Testing

Air flow tests to BS848:Part 1 1980

Noise tests to BS848:Part 2 1985

Wiring Diagram

For MV units see page N-8, diagrams ER 4, 6.

For AD/E units see page N-6/7, diagrams DD 4, 5, 6, 7.

SUGGESTED SPECIFICATION

The axial roof units shall be of the Alpha Supply Series as designed and manufactured by Fantech Pty Ltd.

The axial impellers shall be of powder-coated galvanised steel or GRP (unless specified otherwise) and driven by speed-controllable motors with integral thermal protection. The impellers run in pressed steel plates ensuring a certifiable performance.

The cowl shall be constructed from UV-stabilised plastic and steel components shall be corrosion protected.

All models shall be fully tested to BS848:Part1, 1980 for air flow and BS848:Part 2, 1985 for noise.

ANCILLARY EQUIPMENT

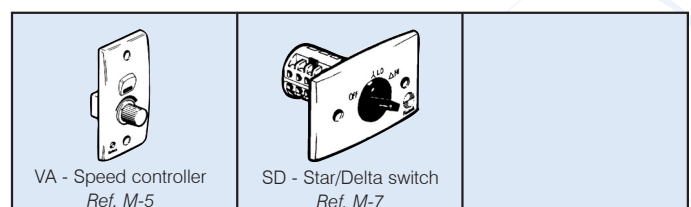

ALPHA SUPPLY SERIES

D

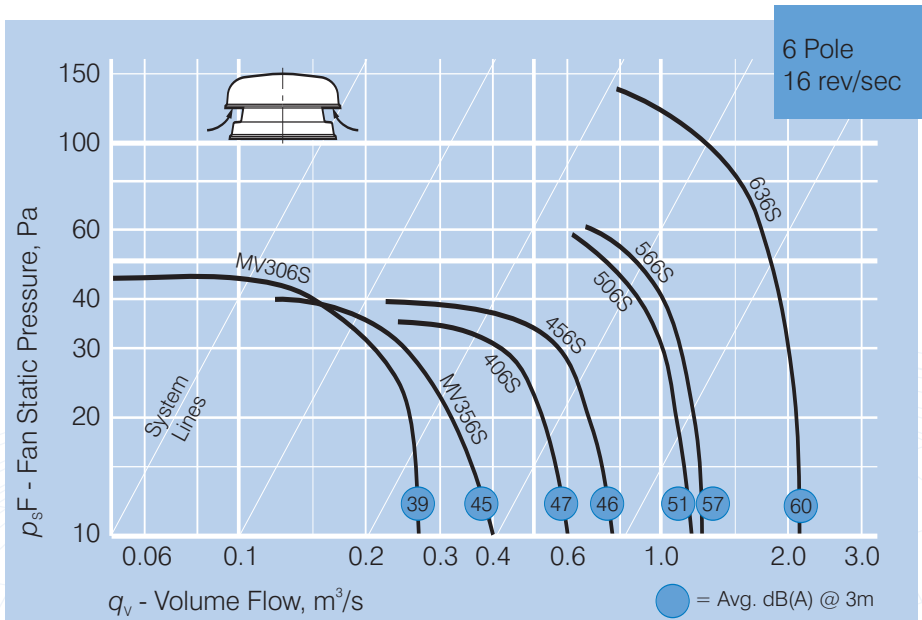
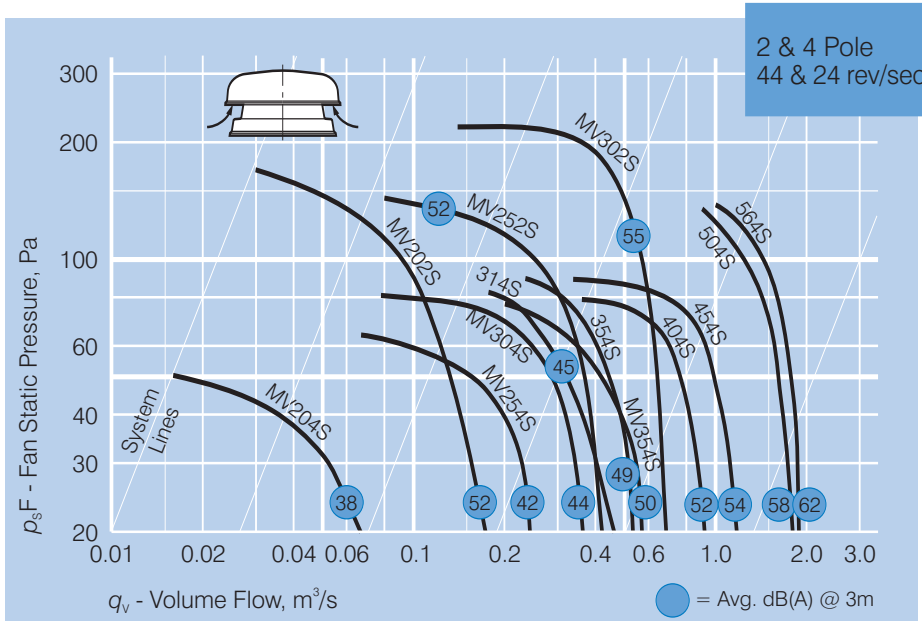

HOW TO ORDER

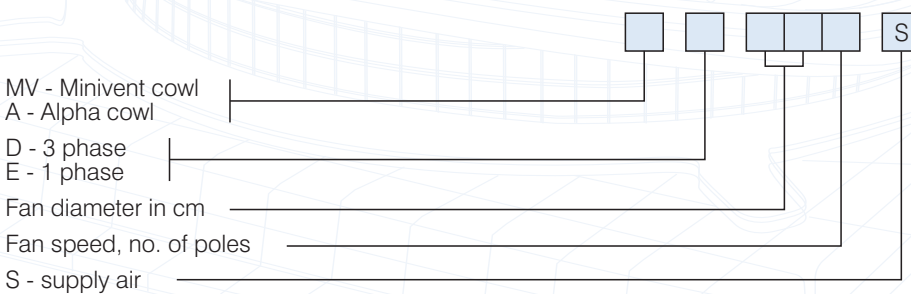

Scan the QR code to view more information online.



TECHNICAL DATA & NOISE LEVELS

Model Number	Nom. Fan Speed rev/sec	Avg. dB(A) @ 3m	MV... 1 ph.			In-duct Sound Power Levels L _w dB re 1pW						
			Watts	Amps*	Max °C	63	125	250	500	1k	2k	4k
MV202S	43	52	70	0.36	50	67	69	73	71	66	65	59
MV204S	24	38	30	0.14	60	53	65	59	57	52	47	39
MV252S	42	51	110	0.63	50	66	72	73	69	65	63	58
MV254S	23	42	60	0.28	60	62	67	67	60	56	52	45
MV302S	41	55	180	0.79	50	67	74	74	75	70	67	64
MV304S	22	44	90	0.41	50	66	67	67	63	58	54	49
MV306S	16	39	50	0.23	50	58	64	64	54	47	53	39
MV354S	20	50	140	0.68	50	67	72	73	65	65	63	57
MV356S	17	45	110	0.48	50	60	66	70	64	57	56	46

Model No. AD... 3 ph. AE... 1 ph.	Nom. Fan Speed rev/sec	Avg. dB(A) @ 3m	AE... 1 ph.		AD... 3 ph.		Max. °C**	In-duct Sound Power Levels L _w dB re 1pW							
			kW	Amps*	kW	Amps*		63	125	250	500	1k	2k	4k	8k
314S	22	45	0.09	0.90	0.12	0.50	70	69	67	63	63	60	57	53	49
354S	21	49	0.09	0.90	0.12	0.50	70	71	70	65	67	66	59	55	54
404S	23	52	0.25	1.80	0.37	1.40	70	71	72	68	70	69	64	61	56
406S	16	47	0.12	1.05	0.16	0.93	70	68	66	64	64	65	59	54	47
454S	22	54	0.25	1.80	0.37	1.40	70	74	75	72	71	70	67	64	56
456S	16	46	0.12	1.05	0.16	0.93	70	66	64	66	64	61	58	54	45
504S	23	58	0.55	3.60	0.55	1.75	70	77	81	78	73	72	72	69	62
506S	16	51	0.18	1.55	0.25	0.94	70	72	67	69	68	69	63	57	51
564S	22	62	0.75	4.90	0.75	2.00	70	81	83	80	79	78	75	73	67
566S	16	57	0.25	2.20	0.25	0.94	70	76	73	76	76	73	71	60	56
636S	16	60	0.55	6.00	0.75	2.88	70	83	80	78	77	76	73	68	59

Electrical data in **bold** type refers to fans fitted with 2-speed star/delta motors as standard

Sound Power Levels shown are for the Inlet Side of the unit.

* Amperages shown are a guide only, refer to our Sales Department for accurate figures at time of order.

** Maximum ambient when being speed controlled is 50°C

DIMENSIONS

MV..S

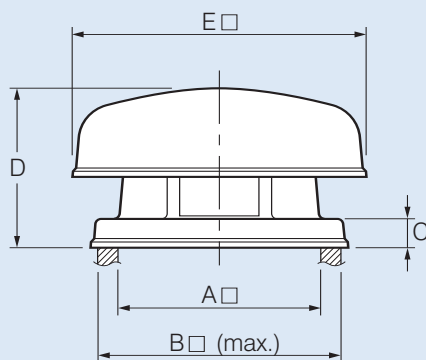

AD/E..S

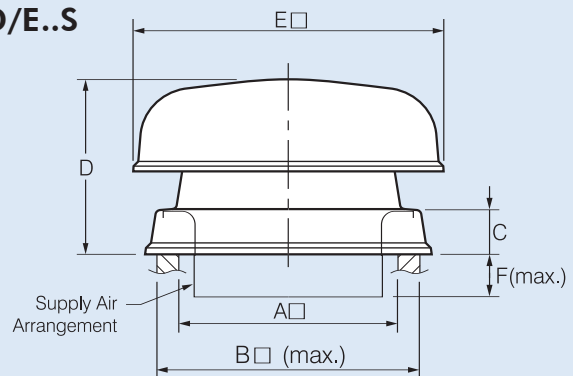

Model Number MV...	Dimensions, mm					App. wt. kg.	App. vol. m³
	A	B	C	D	E		
202S						4.6	
204S						4.5	0.14
252S	350	410	55	350	570	5.9	
254S						6.1	
302S						6.9	
304S	350	410	55	350	570	6.5	0.14
306S						6.5	
354S						8.5	0.20
356S	400	500	95	380	670	8.5	

Model AD.. AE..	Dimensions, mm						App. wt. kg	App. vol. m³
	A	B	C	D	E	Fmax		
31.S							10	
35.S	400	500	95	380	670	10	12	0.20
40.S							16	0.32
45.S	510	610	90	450	770	25	18	
50.S							28	
56.S	670	770	90	560	890	30	34	0.52
63.S	780	980	85	640	1180	45	50	1.10