

A Stylish and Modern Design



The **Hunter Stingray** sweep fan features a sleek, contemporary design that is well suited to indoor commercial applications and large open plan living spaces.



FANTECH
Intelligent Ventilation

Hunter Stingray Sweep Fan

The Hunter Stingray brings together a high-performance ceiling fan with a stylish and modern design. With a 152cm span, its blade pitch is optimized for maximum efficiency and air movement. The Stingray comes with optional integrated LED light and features a chic, charcoal grey or porcelain white finish.

Features

- Reversible, quiet DC motor for optimal performance in summer and winter.
- Comes with an 18-watt dimmable LED light that can be capped if not required (included in kit).
- Pre-balanced for smoother, low noise operation.
- Remote control with 6 fan speeds and light dimmer.
- Comes standard with a 5cm and 23cm down rod.
- Limited Lifetime Warranty.



Remote Control



Dimensions

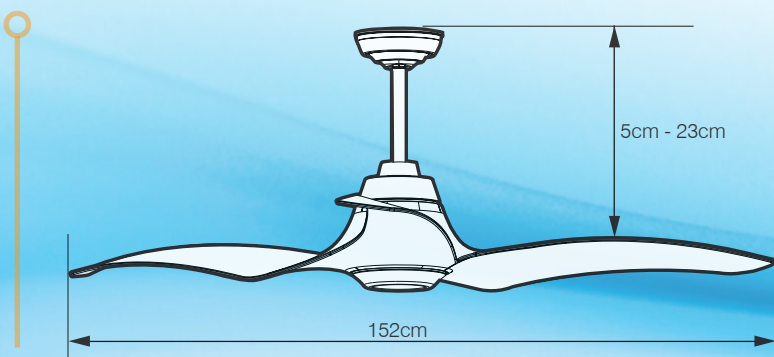

Technical Data

Model No.	HUNTER-SR60BK HUNTER-SR60WH
Max Air flow	3.15 m ³ /s
Max Watts	21
Max RPM	167
LED Light	1520 Lumens
Fan Hang Weight	11 kg



FANTECH
Intelligent Ventilation

Fantech Pty. Ltd.

Victoria:	(+61 3) 9554 7845
New South Wales:	(02) 8811 0400
South Australia:	(08) 8294 0530
Northern Territory:	(08) 8947 0447
Queensland:	(07) 3299 9888
Western Australia:	(08) 9209 4999
A.C.T.	(02) 6280 5511
Tasmania	(03) 6273 6455
New Zealand:	(09) 444 6266

www.fantech.com.au | [Twitter](#) | [LinkedIn](#) | [Facebook](#) | [YouTube](#)

For sales enquiries contact:

Specifications and design subject to change without notice.

A MEMBER OF **eg** ELTA GROUP